

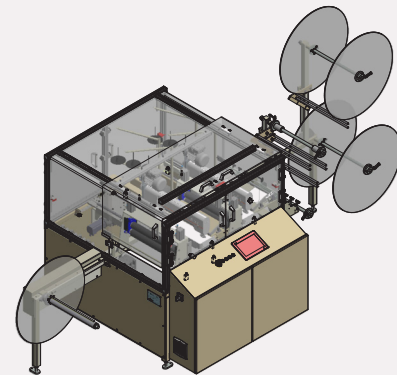

## ***GS-VBM480-DH***

### *Vertical Stitch Border Machine*

High-volume border production from Gribetz.  
Create stylish, Engineered Borders™ with this single-lane border-quilting machine.

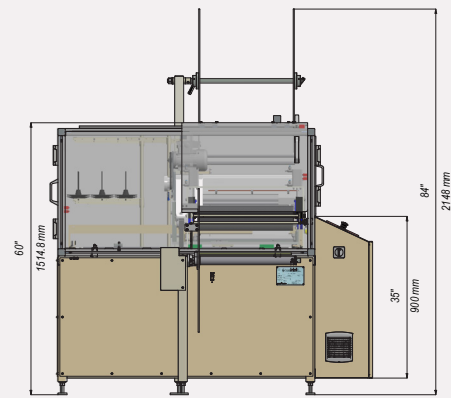
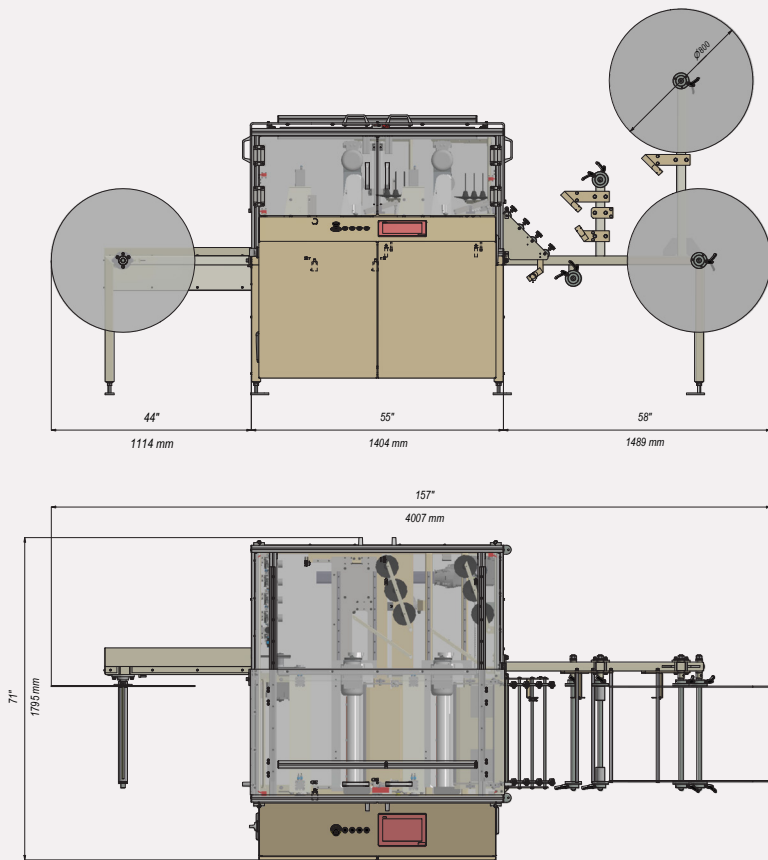

SPECIFICATIONS	GS-VBM480-DH
Speed – max rpm	3000SPM
Maximum finished material width	18" (480mm)
Minimum finished material width	4.75" (125mm)
Maximum material thickness	1.2" (30mm) foam or 10.5oz (300gm) of polyester
Stitch length	4-10 spi (2.5-6.5mm)
Recommended stitch length	7 spi (3.5mm)
Needle size	System UY 128 GAS size 150
Air pressure (psi/bar)	90 psi (6bar)
Air consumption (CFM)	0.5 cfm
Current (amps)	12 amps
Voltage	380 volts 3ph 50Hz
CE approved	yes
Machine weight	830kg/1,830 lbs

The GS-VBM480-DH is a high-performance vertical stitch border machine built of sturdy construction for dependable, high-speed production.

- Vertical stitch border quilter with (2) Pfaff high-speed double-lock chainstitch sewing heads.
- Accepts border widths 150mm (6") - 505mm (19.5").
- Creates sewn vertical lines or V-shaped patterns.
- Efka needle positioner motors.
- Fully integrated material rewind, top, and bottom-thread break detectors.
- Smooth sewing-head movement and material infeed dispenser for quick-and-easy material loading.
- High-quality oil-free pneumatic system.

Gribetz® is the world's leading mattress machinery manufacturer with over a century of experience in machine design. Through rigorous stress and strain analyses, and 3D modeling, our engineering team prides itself in building the most durable state of the art machinery in the industry. We specialize in manufacturing high tech computerized quilting machines, panel cutters, automated and conventional sewing machines, material handling solutions, and mattress-packaging equipment. Call for more information today!

800-326-4742 • 954-846-0300 • Gribetz.com

 **Gribetz**

131 Zapletal Way  
Carthage, MO 64836 USA